



# LLT wood

DESIGN  
DANTE O. BENINI  
E LUCA GONZO

modello registrato  
registered model

portata sul piano: 150 kg  
load capacity on top: 150 kg

Tavolo con piano in legno multistrato marino da 40 mm impiallacciato noce canaletto, rovere "old" o rovere termotrattato, oppure in legno spatolato a mano con Ecomalta ad effetto materico, disponibile in diversi colori: Argilla, Fango M25, Calce M42. Spatulatura tipo materica. Struttura in vetro trasparente o extralight stratificato qda 30 mm e gambe in vetro trasparente o extralight da 19 mm.

Table with top in 40 mm multilayered marine plywood veneered, canaletto walnut or "old style" oak finish or heat-treated oak finish, or in wood hand-finished with Ecomalta for textured effect, available in various colours: Clay brown MAR, Mud brown M25, Lime grey M42. Rough texture finish. Structure in 30 mm layered glass, transparent or extralight and legs in 19 mm transparent or extralight glass.

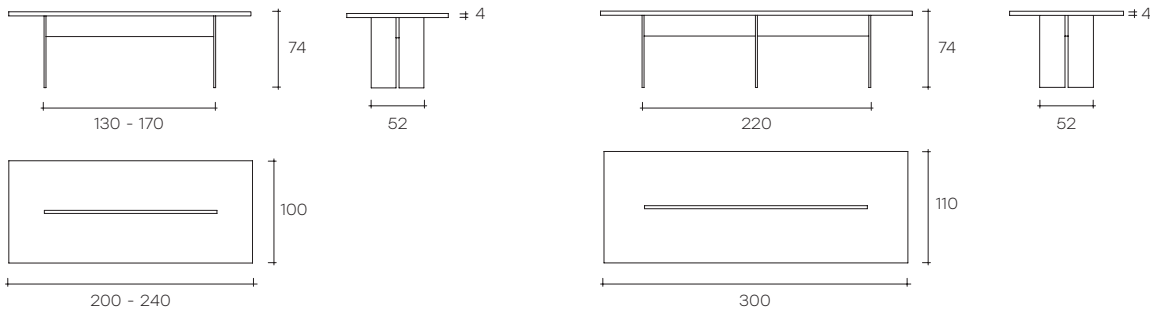

dimensioni L, P, H dimensions L, W, H (cm)	COD./CODE	L	P/W	H	peso netto net weight (kg)	peso lordo gross weight (kg)	volume imballo package volume (m <sup>3</sup> )
Piano impiallacciato noce canaletto. Top in canaletto walnut finish.	<b>LLTW/2010N</b>	200	100	74	96	148	1,35
	<b>LLTW/2410N</b>	240	100	74	113	175	1,67
	<b>LLTW/3011N</b>	300	110	74	156	236	2,16
Piano impiallacciato noce canaletto. Base in vetro extralight. Top in canaletto walnut finish. Extralight glass base.	<b>LLTW/2010XN</b>	200	100	74	96	148	1,35
	<b>LLTW/2410XN</b>	240	100	74	113	175	1,67
	<b>LLTW/3011XN</b>	300	110	74	156	236	2,16
Piano impiallacciato rovere "old". Top in "old style" oak finish.	<b>LLTW/2010RO</b>	200	100	74	96	148	1,35
	<b>LLTW/2410RO</b>	240	100	74	113	175	1,67
	<b>LLTW/3011RO</b>	300	110	74	156	236	2,16
Piano impiallacciato rovere "old". Base in vetro extralight. Top in "old style" oak finish. Extralight glass base.	<b>LLTW/2010XRO</b>	200	100	74	96	148	1,35
	<b>LLTW/2410XRO</b>	240	100	74	113	175	1,67
	<b>LLTW/3011XRO</b>	300	110	74	156	236	2,16



dimensioni L, P, H dimensions L, W, H (cm)	COD./CODE	L	P/W	H	peso netto net weight (kg)	peso lordo gross weight (kg)	volume imballo package volume (m <sup>3</sup> )
Piano impiallacciato rovere termotrattato. <i>Top in heat-treated oak-finish.</i>	<b>LLTW/2010RT</b>	200	100	74	96	148	1,35
	<b>LLTW/2410RT</b>	240	100	74	113	175	1,67
	<b>LLTW/3011RT</b>	300	110	74	156	236	2,16
Piano impiallacciato rovere termotrattato. Base in vetro extralight. <i>Top in heat-treated oak-finish. Extralight glass Base.</i>	<b>LLTW/2010XRT</b>	200	100	74	96	148	1,35
	<b>LLTW/2410XRT</b>	240	100	74	113	175	1,67
	<b>LLTW/3011XRT</b>	300	110	74	156	236	2,16
Piano spatolato in Ecomalta. <i>Hand-finishes Ecomalta wood top.</i>	<b>LLTW/2010EC</b>	200	100	74	96	148	1,35
	<b>LLTW/2410EC</b>	240	100	74	113	175	1,67
	<b>LLTW/3011EC</b>	300	110	74	156	236	2,16
Piano spatolato in Ecomalta. Base in vetro extralight. <i>Hand-finishes Ecomalta wood top. Extralight glass base.</i>	<b>LLTW/2010XEC</b>	200	100	74	96	148	1,35
	<b>LLTW/2410XEC</b>	240	100	74	113	175	1,67
	<b>LLTW/3011XEC</b>	300	110	74	156	236	2,16

FINITURE FINISHES	Top in legno spatolato in Ecomalta, spatolatura tipo materica <i>Wood top hand-finished with Ecomalta, rough texture finish</i>		
	Argilla Clay	Fango Mud	Calce Lime
CODICE CODE	<b>MAR</b>	<b>M25</b>	<b>M42</b>

## PIANI CUSTOM \_ CUSTOM TOPS

Tavolo LLT Wood è realizzabile anche con dimensioni a misura.  
*Custom size LLT Wood available on request.*

GAMBA LEG	MISURA MINIMA DEL TOP MINIMUM DIMENSION OF THE TOP	MISURA MASSIMA DEL TOP MAXIMUM DIMENSION OF THE TOP
L cm 90X45	160X80	180X90
L cm 130X52	190x100	220x120
L cm 170x52	230x100	280x120
L cm 220x52	290x100	305x120



---

**FINITURE  
FINISHES**

---

**Piano in legno  
Wood top**



noce canaletto  
canaletto walnut



rovere "old"  
"old style" oak



rovere termotrattato  
heat-treated oak

**Piano in legno spatolato con Ecomalta®  
Ecomalta® hand-finished wood top**



argilla  
clay brown

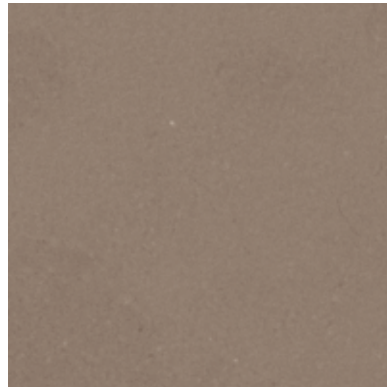

fango  
mud brown

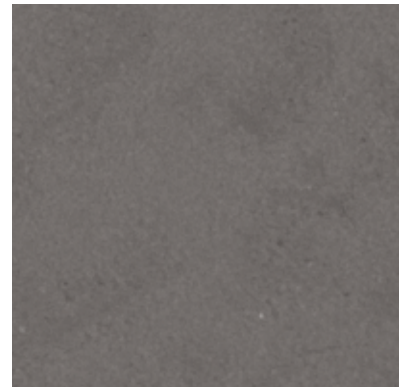

calce  
lime grey